

## Blow macetero 100x100x75

por Stefano Giovannoni

La colección Blow, diseñada por Stefano Giovannoni, presenta una innovadora propuesta de mobiliario en sintonía con la familia Pillow, con un enfoque fresco y distintivo. Esta colección in&out redefine la funcionalidad del diseño de exteriores e interiores, ofreciendo piezas que combinan confort y estilo con una elegancia única.



## Info

---

### Descripción

Macetero fabricado con resina de polietileno mediante moldeo rotacional con doble pared. 100% Reciclable. Apto para exterior e interior. Disponible en varios acabados.

Peso: 25.08 Kg

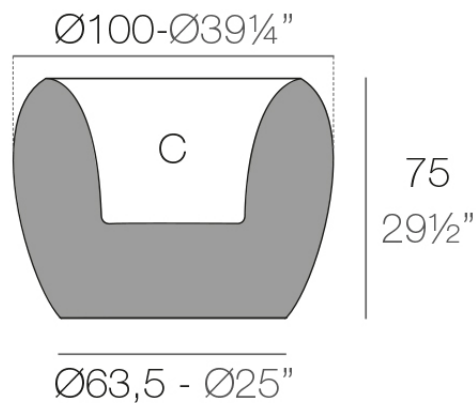

BLOW Macetero 100x75

C = 104 L

BLOW Planter 100x75

C = 27½ gal

## Acabados

---

### acabados

---

#### BASIC

Ref. 55021A



white 2001



ecru 2003



tortora 2004



cream 2017



camel 2020



clay 2022



garnet 2015



brown 2008



green 2016



blue 2018



gray 2005



anthracite 2006



black 2002



ecru granite



cream granite



ice 2101

Resina de polietileno acabado mate.

#### AUTORRIEGO

Ref. 55021R

# VONDOM



white 2001



ecru 2003



tortora 2004



cream 2017



camel 2020



clay 2022



garnet 2015



brown 2008



green 2016



blue 2018



gray 2005



anthracite 2006



black 2002



ecru granite



cream granite



ice 2101

Sistema de autorriego en todos los acabados a excepción de BASIC.

## LACADO

Ref. 55021F



white 3101



ecru 3103



tortora 3104



cream 3117



garnet 3113



brown 3125



green 3116



blue 3118



gray 3105



anthracite 3106



black 3102

Resina de polietileno con un acabado lacado brillo.

## luz

---

LED BLANCO

Ref. 55021W



ice 2101

Con iluminación interior de color blanco mediante tecnología LED. Solo disponible en acabado hielo mate.

LED RGBW

Ref. 55021L



ice 2101

Con iluminación interior mediante tecnología LED RGBW y mando a distancia para cambiar de color. Solo disponible en acabado hielo mate. Acompañado de un mando a distancia para el cambio de color\* por selección o de forma automática.

## LED RGBW DMX

Ref. 55021D

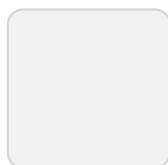

ice 2101

Con iluminación interior mediante tecnología LED RGBW y mando a distancia para cambiar de color. Controlado también por DMX-1024 (wireless). Solo disponible en acabado hielo mate. permitiendo la comunicación entre uno o multiples productos simultaneamente mediante el transmisor DMX (no incluido). Hay dos opciones para seleccionar. Professional XLR DMX y Home WIFI DMX.

## LED RGBW BATERIA

Ref. 55021Y

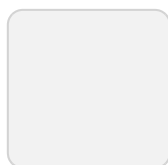

ice 2101

Con iluminación interior mediante tecnología LED RGBW, alimentado por una batería. Se incluye mando a distancia para cambiar de color y cargador. Solo disponible en acabado hielo mate.

## LED RGBW DMX BATERIA

Ref. 55021DY

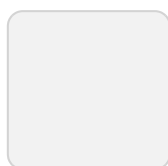

ice 2101

Con iluminación interior mediante tecnología LED RGBW, alimentado por una batería. Incluye mando a distancia para cambiar de color. Controlado también por

# VONDOM

DMX-1024 (wireless). Solo disponible en acabado hielo mate. permitiendo la comunicación entre uno o multiples productos simultaneamente mediante el transmisor DMX (no incluido). Hay dos opciones para seleccionar. Professional XLR DMX y Home WIFI DMX.

## Ambients

---

