

## Vineyard macetero xl ruedas

por Ramón Esteve

La colección Vineyard, diseñada por Ramón Esteve, captura la esencia del estilo mediterráneo, combinando elegancia y comodidad en cada una de sus piezas. Inspirada en los viñedos y la vida al aire libre, esta colección es perfecta para crear ambientes relajados y acogedores.



## Info

---

### Descripción

Peso: 43.7 Kg

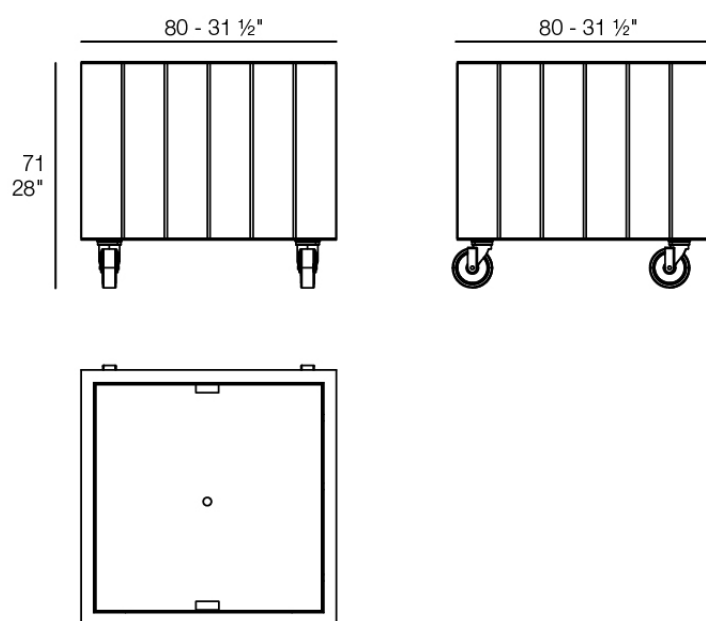

VINEYARD Maceta 800 x 800 C = 248 L  
VINEYARD Planter 31 1/2" x 31 1/2" C = 65 gal

## Acabados

---

### acabados

---

ALUMINIO  
Ref. 54509SU

### panel/top

---

ALUMINIO  
Ref. 54509AA



white



smoked

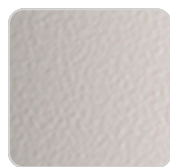

ecru



tortora



cream



garnet



brown



green



blue



anthracite



black

Perfil de aluminio en acabado lacado.

Teca

# VONDOM

Ref. 54509AA



natural teka



weathered teka

