

## Agatha mesa

by Agatha Ruiz de la Prada

La colección Agatha, concebida por Agatha Ruiz de la Prada para Vondom, es un manifiesto de alegría y vitalidad en cada pieza. Inspirada en las formas frescas y desenfadadas que definen el estilo de la diseñadora, Agatha transforma cualquier espacio en un rincón lleno de diversión y creatividad, invitando a redescubrir el placer de estar al aire libre.



## Info

---

### Description

Fabricado con resina de polietileno mediante moldeo rotacional con doble pared. 100% Reciclable. Apto para exterior e interior. Disponible en varios acabados.

Weight: 14 Kg

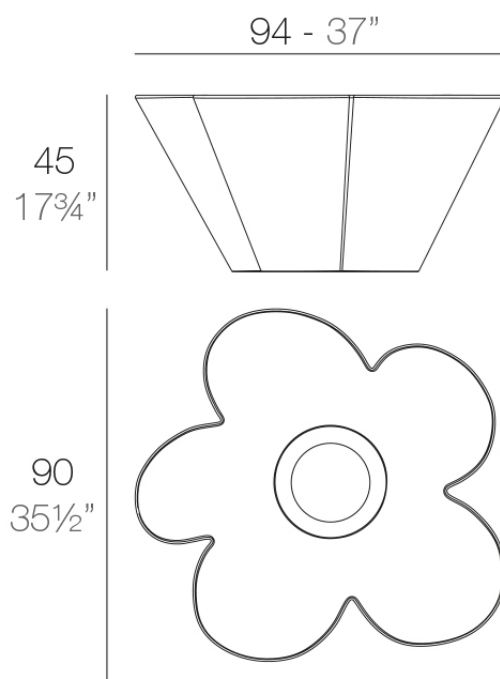

AGATHA Mesa Baja (incluye portaplápices)  
AGATHA Low Table (pencil case included)

## Finishes

---

### acabados

---

#### BASIC

Ref. 52002



white 2001



ecru 2003



tortora 2004



cream 2017

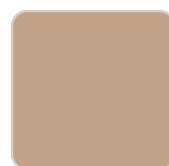

camel 2020



clay 2022



garnet 2015



brown 2008



green 2016



blue 2018



gray 2005



anthracite 2006



black 2002



ecru granite



cream granite



ice 2101

Resina de polietileno acabado mate.

#### LACADO

Ref. 52002F

# VONDOM



white 3101



ecru 3103



tortora 3104



cream 3117



garnet 3113



brown 3125



green 3116



blue 3118



gray 3105



anthracite 3106



black 3102

Resina de polietileno con un acabado lacado brillo.

BICOLOR LACADO

Ref. 52002FP

Resina de polietileno con un acabado lacado brillo bicolor

## Ambients

---

